



Greenough

Greenough Enterprises Co., Ltd.

LED luminaries Manufacturer and Exporter

Round UFO LED High Bay Light Specification

Product: Round UFO Led High Bay Light

Model No.: GNH-R-HBL-100W; GNH-R-HBL-150W; GNH-R-HBL-200W

Dimension(mm): 300*300*182; 360*360*198; 360*360*207

Date: Apr 15th, 2016





I. Product Introduction

Characteristics

1. **Energy saving.** Saving 50% energy than the conventional Metal halide lamp, Sodium Light.
2. **Long life and environmental protection.** LED high bay light uses LEDs with long lifetime more than
3. 50,000 hours. It has no ultraviolet radiation. It offers full environmental protection. It has no hazardous materials like mercury or lead entering the environment.
4. **Input voltage:** AC90~305V, Over voltage, over current protection.
5. They also could be dimming in 0-10V or Dali Dimming
6. **Good heat dissipation.** Adopt high thermal conductivity aluminum shell, laminated structure, thermal conductive area is fully, IP 65
7. **Low heat.** The total power consumption is less than half of the traditional industrial lights.
8. New design, with lighter weight, better heat dissipation, more stable quality, easy to install
9. The main accessories are imported materials, anti-high temperature and anti-corrosion
10. The led chips are the imported high brightness chips, with higher lumen output, high thermal conductivity, low luminous decay, pure light color, no ghosting etc
11. The lamps are with the angle locking device, to ensure the angle won't be changed for the long-term working in the vibration environment
12. Using the latest technology of heat radiation structure, can ensure lamp life
13. With pedestal, pendant, pole, Chain, Bracket etc installation methods.



II. Specifications, parameters

1. LED high bay light technical parameters

Part Number		GNH-R-HBL-100W	GNH-R-HBL-150W	GNH-R-HBL-200W
Power (W)		100W	150W	200W
Input voltage(V)		90-305VAC		
Input Current		0.46A@220VAC	0.62A@220VAC	0.91A@220VAC
PF		>0.95@220VAC		
DC V out		50-60VDC		
DC V out		1.6A	2.45A	3.3A
CCT		Warm (4000K/Ra80) ,White (5700K/Ra70 and Ra80)		
Ra >80	Typical Flux	10000 Lm±10%	18750 Lm±10%	22000 Lm±10%
Ra >70	Typical Flux	11000 Lm±10%	20250 Lm±10%	24000 Lm±10%
LED Qty (pcs)		117	234	234
LEDBrand		Nichia3030		
Beam Angle		PC lens with 60°and 90°		
IP Grade		IP65	3000-6000k	3000-6000k
Operation Temp		-40℃ ~ +65℃		
Body Color		Black (MOQ is required for other color demand.)		
Life Span		50000 Hours	50000 Hours	50000 Hours
Product Size(mm)	CEDriver	300*300*156	360*360*172	360*360*172
	Meanwell Driver	300*300*182	360*360*198	360*360*207
Packing Size(mm)	CE Driver	368*368*216	424*424*270	424*424*270
	Meanwell Driver	368*368*216	424*424*270	424*424*270
Mounting Type		Pole (default), Chain (optional), Bracket (optional)		



2. Dimensional Drawing(Unit: mm):

GNH-R-HBL-100W

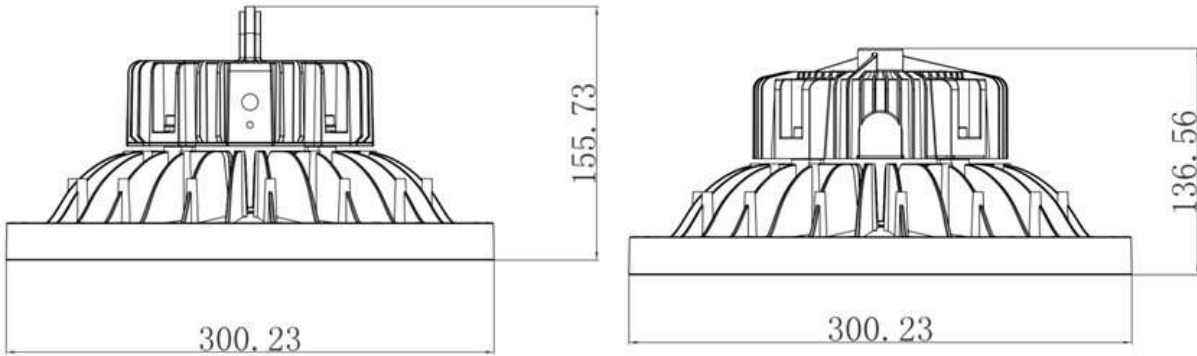

GNH-R-HBL-150W-200W

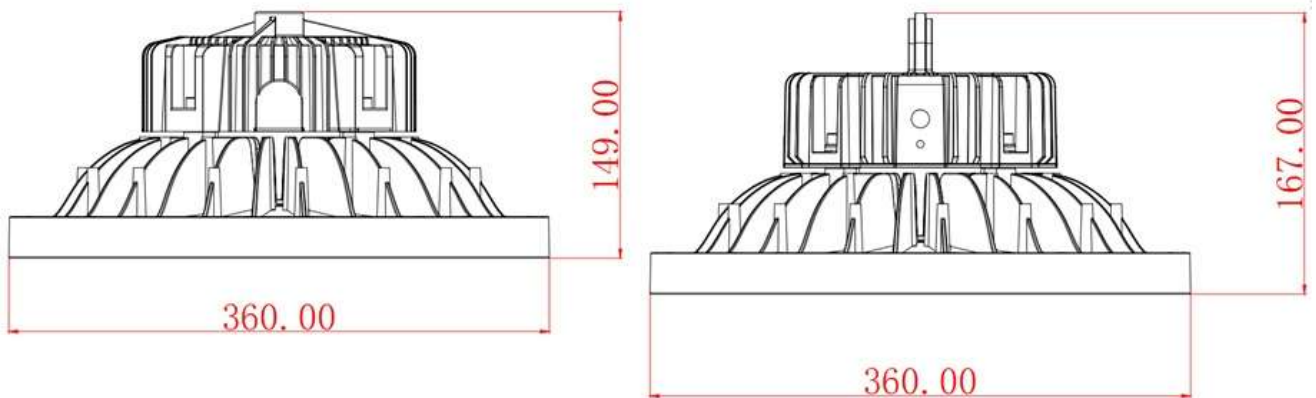



3. Distribution Diagram(100W in 60° and 200 in 90° for reference)

100W-Beam Angle 60°

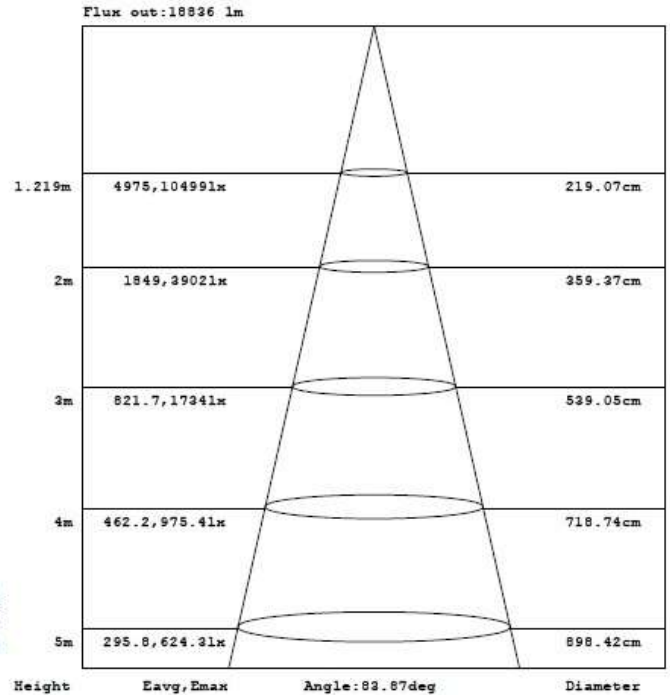
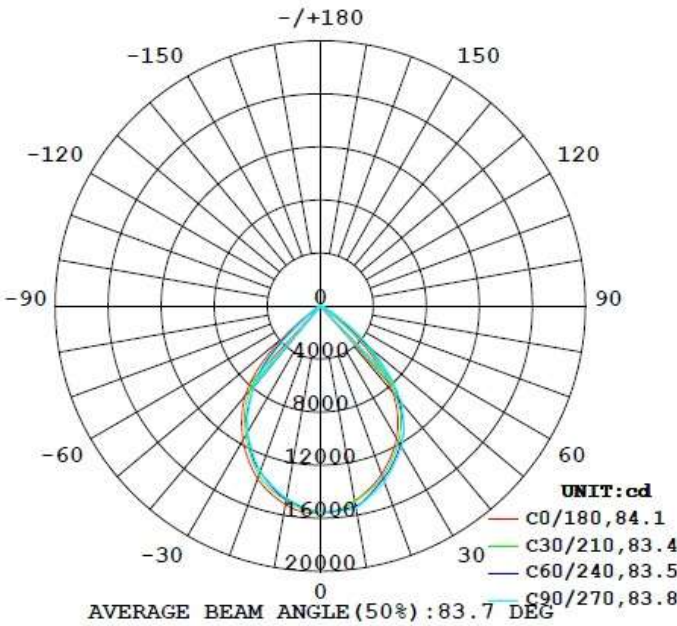
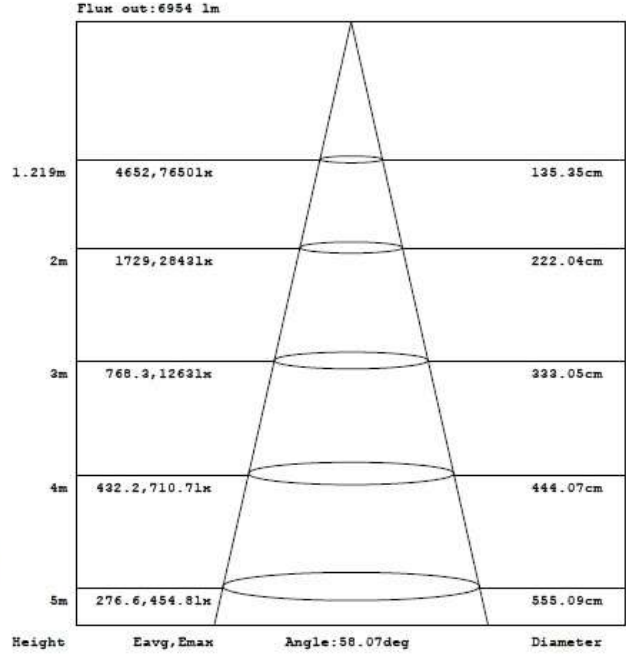
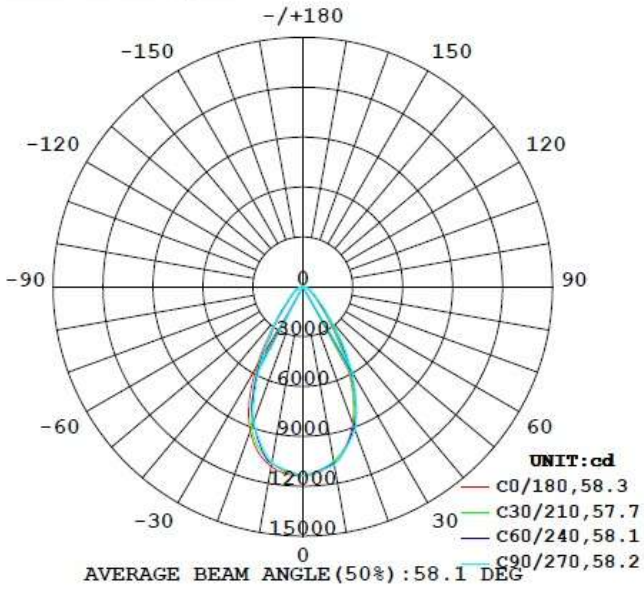



4. Structure Drawing:

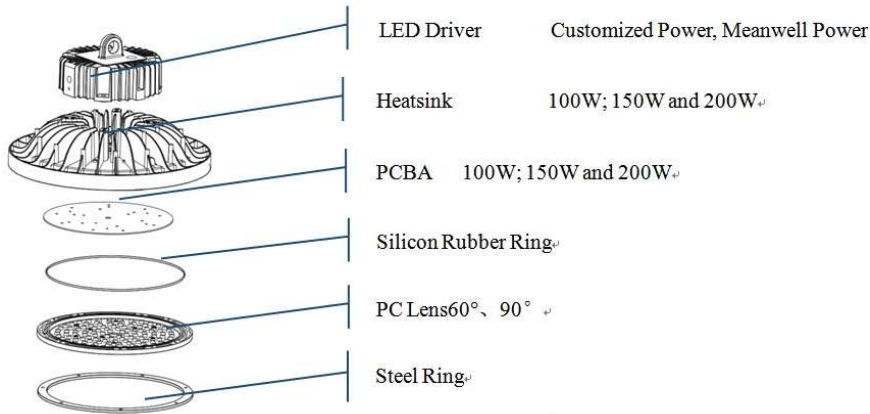

5. User Manual For UFO LED High Bay Light:



- Read through this manual before installation.
- For indoor use only.
- Handle the product with care.
- The product must be grounded.
- This product must be installed and maintained by certified electrician.
- Consult with the manufacturer before maintenance.
- Turn OFF the power before installation and maintenance.
- Make sure the products are securely installed.
- The housing might become hot after operation.
- Make sure the construction is strong enough to support the products.
- The product will automatically shut down once the temperature goes too high; and will automatically turn on once it cools down.
- If the cord of the product is damaged please stop using the product and consult with manufacturer.



6. Installation For UFO LED High Bay Light:

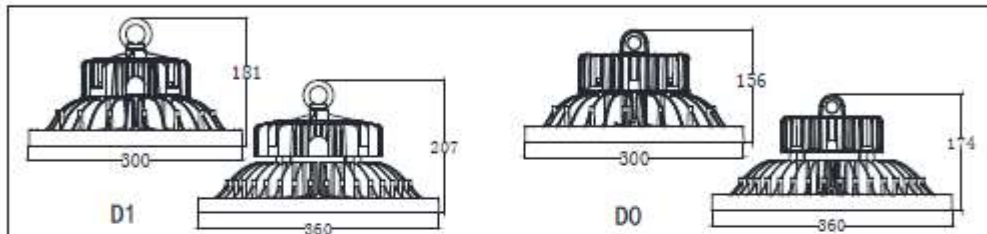
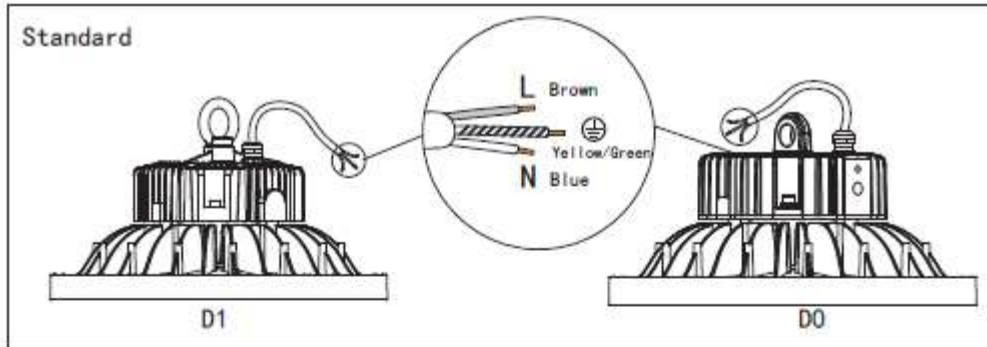

W	L×W×H	NW	GW	LM
100W	D1=300×300×181mm	3.97kg	4.7kg	>11000 Lm
	D0=300×300×156mm	3.90kg	5.0kg	>11000 Lm
150W	D1=360×360×207mm	6.35kg	7.5kg	>18750 Lm
200W	D0=360×360×174mm	5.37kg	6.9kg	>22000 Lm

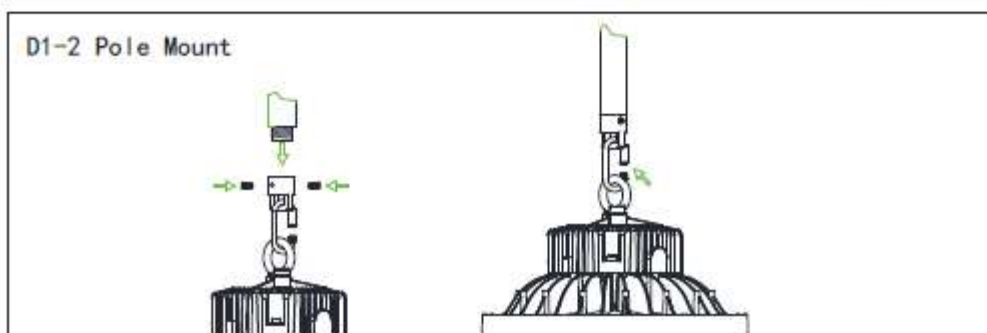
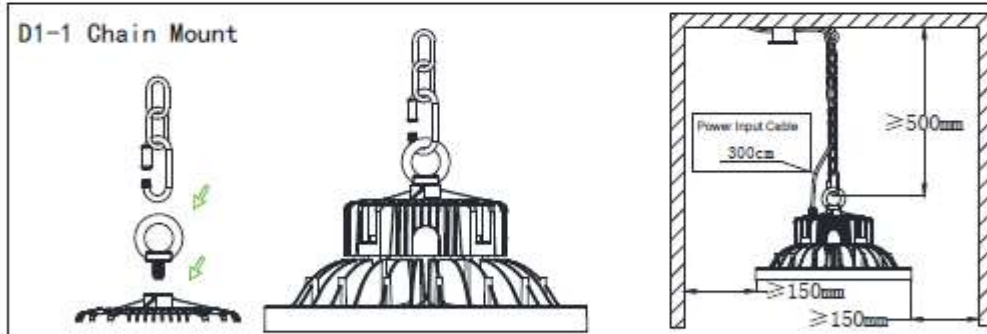

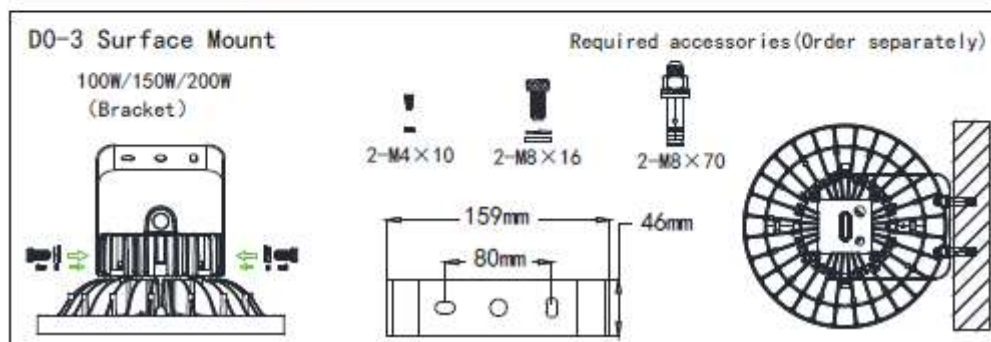
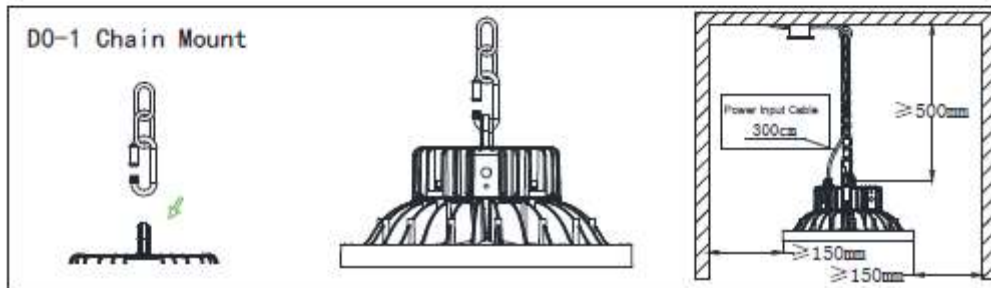
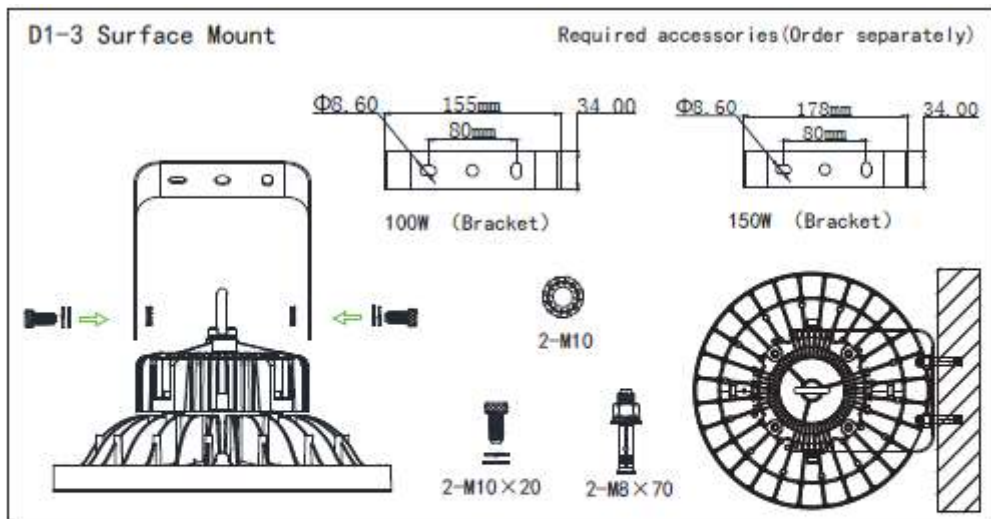



7. Packing for round led high bay light

Part No.	Driver	Packing Box	Gross Weight	Net weight
GNH-R-HBL-100W	CE Driver	368*368*216	4.80Kg	3.90Kg
	Meanwell	368*368*216	4.40Kg	3.50Kg
GNH-R-HBL-150W	CE Driver	424*424*270	6.80Kg	5.40Kg
	Meanwell	424*424*270	7.10Kg	5.70Kg
GNH-R-HBL-200W	CE Driver	424*424*270	6.80Kg	5.40Kg
	Meanwell	424*424*270	7.70Kg	6.30Kg

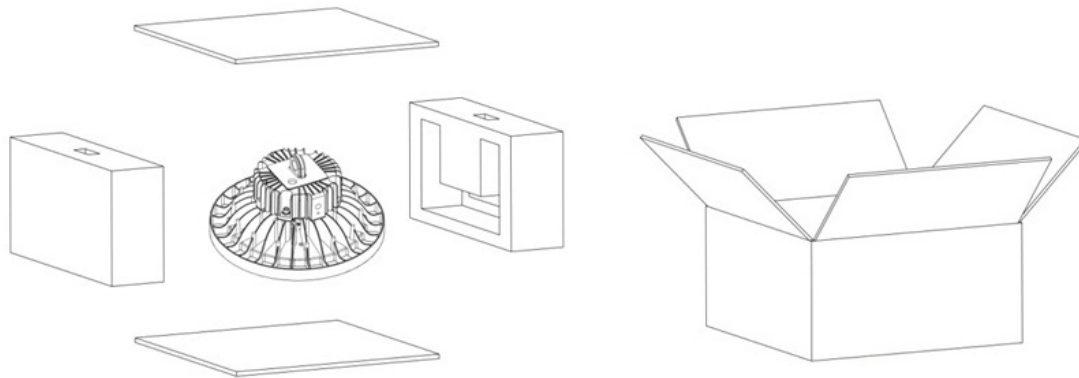

14. Applications

LED High Bay Light are suitable for Warehouse, Workshops, factories, toll stations, gas stations, supermarkets, exhibition halls, gymnasium, etc... and some other places where need industrial lighting.

