



Greenough

Greenough Enterprises Co., Ltd.

LED luminaries Manufacturer and Exporter

Driverless led down light Specification

Product: Driverless SMD led down light

Model No.: GNH-AC-A30-7W; GNH-AC-A40-12W; GNH-AC-A50-15W; GNH-AC-A60-18W; GNH-AC-A80-24W

Dimension: $\Phi 125 \times 40$ mm(7w); $\Phi 140 \times 48$ mm(12w); $\Phi 180 \times 53$ mm(15w); $\Phi 190 \times 53$ mm(18w); $\Phi 230 \times 69$ mm(24w)

Date: Dec 26th, 2014





Greenough

Greenough Enterprises Co., Ltd.

LED luminaries Manufacturer and Exporter

I. Product introduction

Characteristics

1. No driver thus it can avoid the failure of driver
2. Dimmable matching different dimmer control. like PMW, Silicon controlled rectifier,etc almost 85%dimmer
3. Scientific thermal design, longer life span
4. AC LED technology makes LEDs work directly by AC220-240V without any driver, we call it driver-free light. These LEDs can be connected directly to normal power supplies (usually 230V at 50HZ).
5. Original Samsung AC SMD, low life decaying rate
6. Clean and pure light effect, energy saving
7. Warranty : 2 years
8. Driverless, 50,000hrs life span
9. 100% pass CE RoHS certificates for its no ICs Capacitors Inductance and Transformers



II. Specifications, parameters

1. **Driverless LED Down light technical parameters** (***) Note: Different CCT LEDs has different optical properties. The deviation is less than 5% (***)

Model No.	Power	Voltage(AC)	Dimension (MM)	Cut-out-hole(m)	CCT	LED style	Flux(LM)	Beam angle	CRI(Ra)
GNH-AC-A3 0-7W	7W	AC230V	Φ125*H40mm	90	2600-6300K	Samsung SMD	560LM 595LM 630LM	120°	≥80
GNH-AC-A4 0-12W	12W	AC230V	Φ140*H48mm	120	2600-6300K	Samsung SMD	960LM 1020LM 080LM	120°	≥80
GNH-AC-A5 0-15W	15W	AC230V	Φ180*H53mm	150	2600-6300K	Samsung SMD	1350LM 1380LM 1400LM 1420LM	120°	≥80
GNH-AC-A6 0-18W	18W	AC230V	Φ190*H53mm	170	2600-6300K	Samsung SMD	1650LM 1700LM 1730LM	120°	≥80
GNH-AC-A8 0-24W	24W	AC230V	Φ230*H69mm	200	2600-6300K	Samsung SMD	2300LM 2350LM 2400LM	120°	≥80

2. **Brightness Contrast(GNH-AC-A50-15W for your reference):**

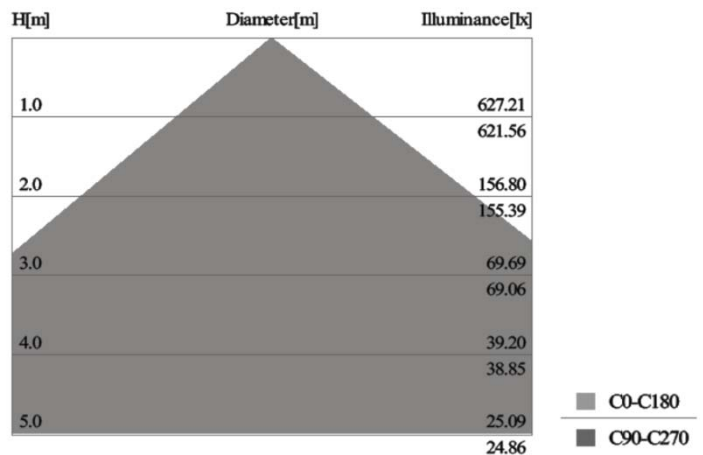
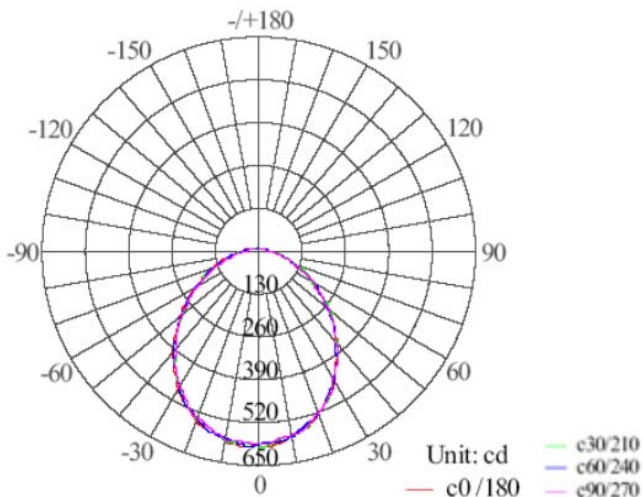



3. LEDs Lumen Attenuation:

Testing condition: None break operation

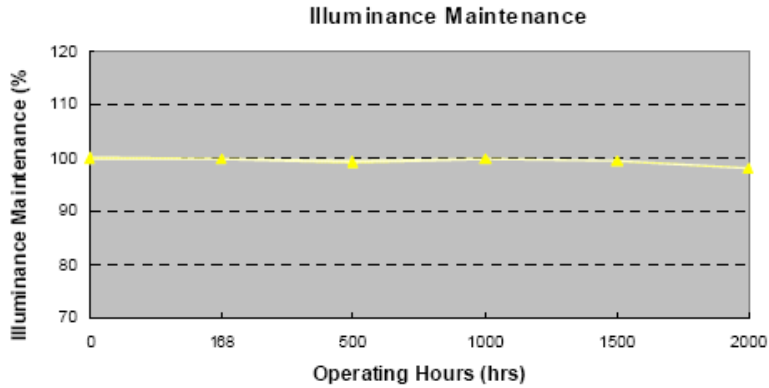

4. Dimensional Drawing(Unit: mm):

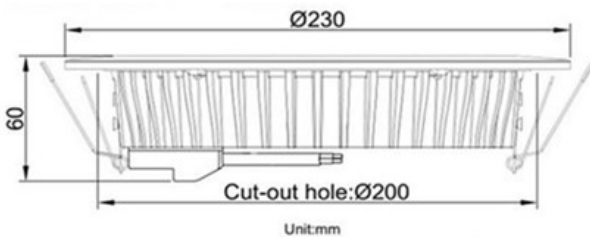
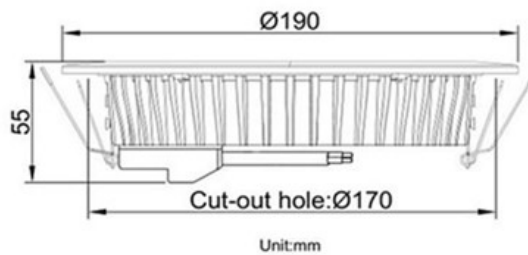
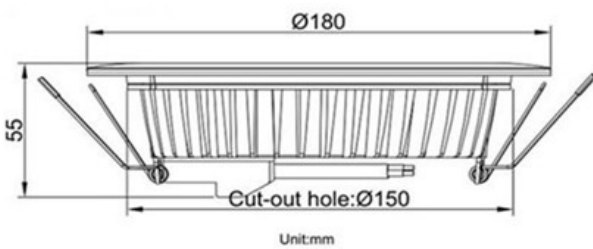
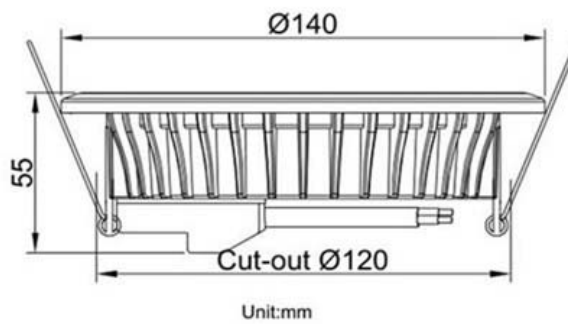
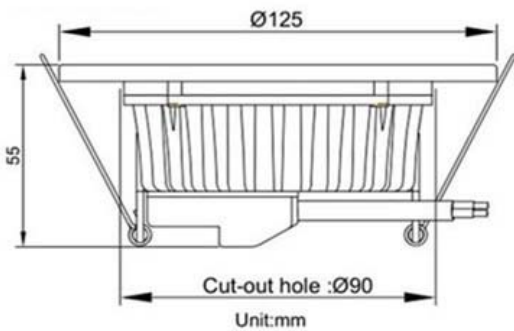



5. Packing details

Part No.	Packing Box	Outer Carton	Gross Weight	Net weight
GNH-AC-A30-7W GNH-AC-A40-12W	145*65*H145mm	350*310*460mm 30pcs/carton	11KGS/CTN	8.5KGS/CTN
GNH-AC-A50-15W GNH-AC-A60-18W	185*65*H185mm	350*390*580mm 20pcs/carton	11.5KGS/CTN	8.4KGS/CTN
GNH-AC-A80-24W	235*70*235mm	370*490*495mm 16pcs/carton	16.5KGS/CTN	12.5KGS/CTN

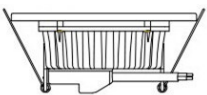

For GNH-AC-A30-7W and GNH-AC-A40-12W

↓ 3 layer

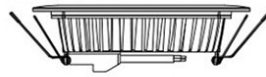
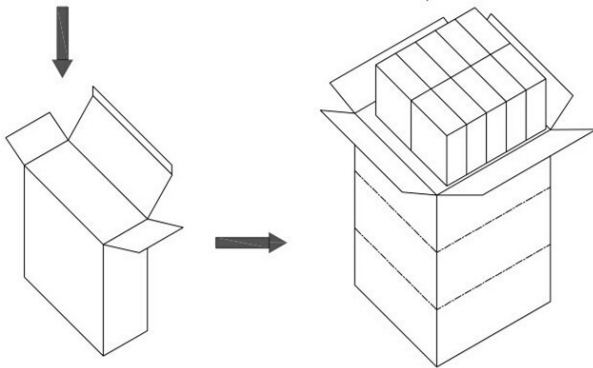

For GNH-AC-A50-15W and GNH-AC-A60-18W

↓ 2 layer

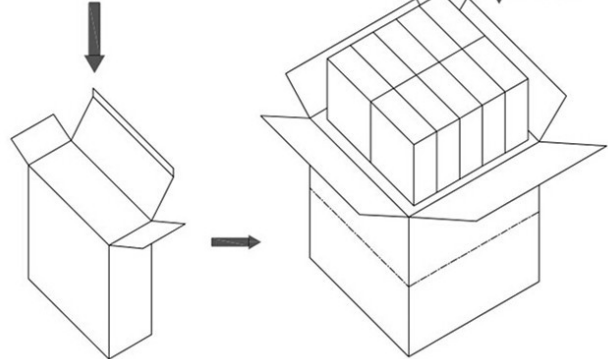

For GNH-AC-A80-24W

↓ 2 layer

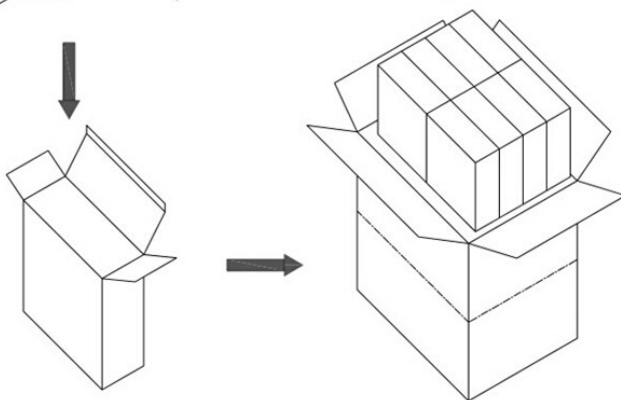



Greenough

Greenough Enterprises Co., Ltd.

LED luminaries Manufacturer and Exporter

6. Application:

As usual they are widely used Hotels, Hospitals, Commercial Complexes, Conference / Meeting rooms, Factories & Offices, Residential / Institution Buildings, Schools and so on.

