



Greenough

Greenough Enterprises Co., Ltd.

LED Luminaries Manufacturer and Exporter

180W 200W Bridgelux led high bay light Specification

Product: 180W 200W Bridgelux led high bay light

Model No.: GNH-MN03-HBL-180W-H0; GNH-MN03-HBL-200W-H0

Beam Angle: 45°/90°/120°

Date: Jan 14th, 2015



45° small reflector



90° small reflector

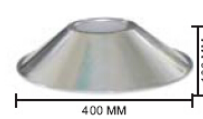

120° small reflector



45° big reflector



90° big reflector

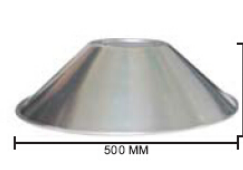

120° big reflector



Greenough

Greenough Enterprises Co., Ltd.

LED luminaries Manufacturer and Exporter

I. Product introduction

Characteristics

1. Using single powerful **Bridgelux chips** as the light source, with unique lighting design of Multi-chip integrated single-module; select for excellent imported semiconductor chip
2. Input voltage: AC90~305V, over voltage, over current protection.
3. Energy saving system, saving 50% energy than the conventional Metal halide lamp, Sodium Light.
4. High thermal conductivity, low luminous decay , longer life span
5. Shell Material: Aluminum Alloy, Shell Color: Black, Grey, Warm and cold color temperature is available
6. Can start up within 1`3 seconds, no flicker, anti-jamming, no mercury, energy saving, environment friendly.
7. IP Grade:IP65
8. 45°/90°/120° beam angle are available.
9. Apply for unique surface treatment technology, well-decorated, novel style, easy to install, lower maintenance cost and wide in application.
10. 100% pass CE RoHS certificates for its no ICs Capacitors Inductance and Transformers

II. Specifications, parameters

1. **Bridgelux LED high bay light technical parameters** (***) Note: Different CCT LEDs has different optical properties. The deviation is less than 5% (***)

Model No.	Power	Input voltage(V)/Driver	Material	CCT	LED chip	Flux(LM)	Beam angle	CRI (Ra)	IP grade
GNH-MN03-HB L-180W-H0	1*180 W	AC90-305 Meanwell	Die-casting+optical glass	2700-7000K	Bridgelux	120-130lm/w	45°/90°/120°	≥75	IP65
GNH-MN03-HB L-200W-H0	1*200 W	AC90-305 Meanwell	Die-casting+optical glass	2700-7000K	Bridgelux	120-130lm/w	45°/90°/120°	≥75	IP65

2. **Brightness Contrast:(45 Degree Beam Angle for Reference)**

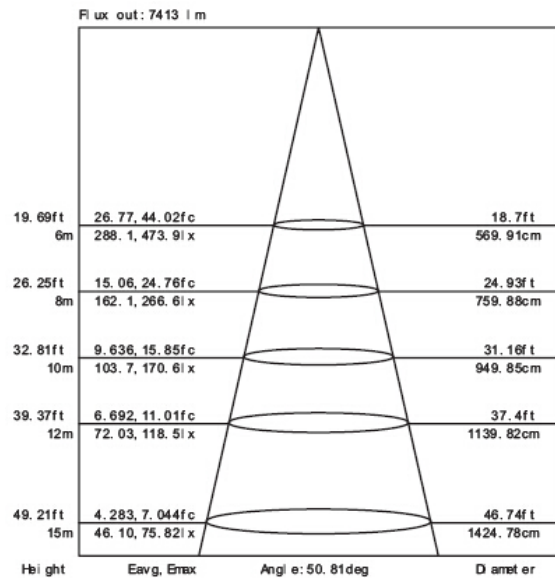
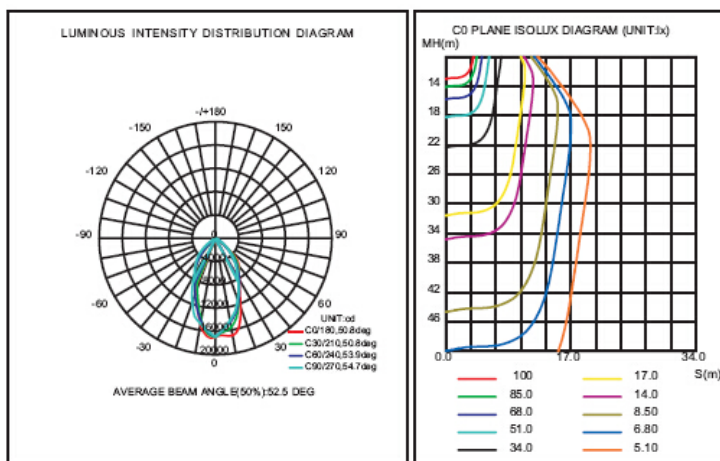

3. **Dimensional Drawing(Unit: mm):**

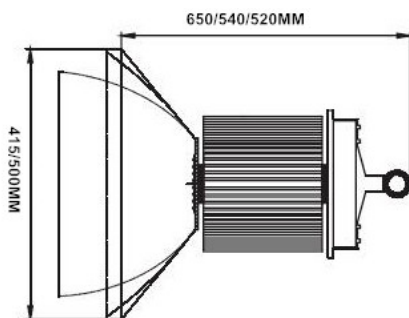

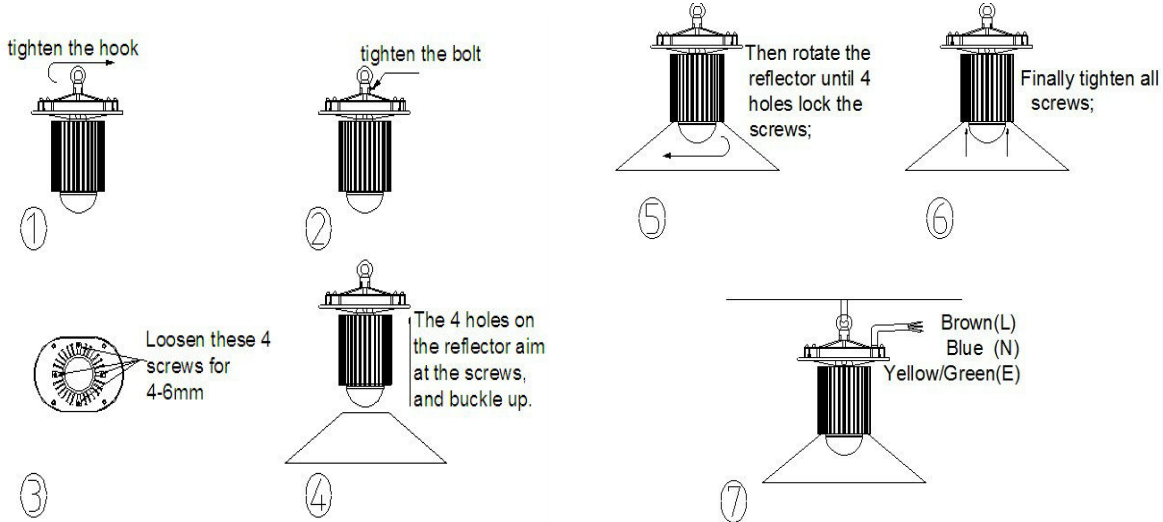
4. Installation:

5. Packing details:

Part No.	Lamp body Packing Box	Reflector Packing Box	Gross Weight(one pc)
GNH-MN03-HBL-180W-H0	470*300*300MM	425*425*695 (20pcs/ctn)	8.30KGS
GNH-MN03-HBL-200W-H0	(20pcs/ctn)	530*530*325(20pcs/ctn)	





Greenough

Greenough Enterprises Co., Ltd.

LED luminaries Manufacturer and Exporter

6. Note:

- *Do Not remove any parts
- *For indoor use only
- *Must be under the required voltage.
- *Can be placed in conventional
- *8-10 hours used per day

7. Application:

LED High Bay Light adopts High quality LED chips source with longer lifespan and low lighting decay LED High Bay Light Application: Suitable for Warehouse, Workshops, factories, toll stations, gas stations, supermarkets, exhibition halls, gymnasium, etc...and some other places where need industrial lighting.

