



Greenough

Greenough Enterprises Co., Ltd.

LED luminaries Manufacturer and Exporter

Waterproof round led down light Specification

Product: Waterproof round led down light

Model No.: GNH-DL-WP-5W-A; GNH-DL-WP-7W-A; GNH-DL-WP-9W-A; GNH-DL-WP-10W-A;
GNH-DL-WP-12W-A; GNH-DL-WP-15W-A; GNH-DL-WP-16W-A

Power: 5W; 7W, 9W, 10W, 12W, 15W, 16W

Dimension: 90*45mm (5W; 7W, 9W,); 108*50mm (10W, 12W, 15W, 16W)

Date: Feb 6th, 2015





Greenough

Greenough Enterprises Co., Ltd.

LED luminaries Manufacturer and Exporter

I. Product introduction

Characteristics

1. High Luminous efficiency;
2. Fast light brightening, no delay and flicker;
3. longer life span: more than 50,000 hours;
4. Energy-saving: saving 80% than the ordinary lamp;
5. Green, Health and Environmentally friendly protection, more comfortable for our vision.
6. Waterproof Grade: IP65
7. No mercury, No radiation, No UV;
8. Easy to install and maintain, no subsidiary fixture;
9. Low consumption and high conversion.
10. Passed CE and ROHS certification;
11. Clean and pure light effect, energy saving



II. Specifications, parameters

1. **Waterproof LED Down light technical parameters** (***) Note: Different CCT LEDs has different optical properties. The deviation is less than 5% (***)

Model No.	Power	Voltage(AC)	Dimension (MM)	Cut-out-hole(m)	CCT	LED style	Flux(LM)	Beam angle
GNH-DL-WP-5 W-A	5W	AC85-265V	90*45MM	Φ75mm	2700-6500K	COB/SMD 5730	430-480LM	120°
GNH-DL-WP-7 W-A	7W	AC85-265V	90*45MM	Φ75mm	2700-6500K	COB/SMD 5730	630-680LM	120°
GNH-DL-WP-9 W-A	9W	AC85-265V	90*45MM	Φ75mm	2700-6500K	COB/SMD 5730	810-870LM	120°
GNH-DL-WP-1 0W-A	10W	AC85-265V	108*50mm	Φ95mm	2700-6500K	COB/SMD 5730	890-960LM	120°
GNH-DL-WP-1 2W-A	12W	AC85-265V	108*50mm	Φ95mm	2700-6500K	COB/SMD 5730	1080-1160LM	120°
GNH-DL-WP-1 5W-A	15W	AC85-265V	108*50mm	Φ95mm	2700-6500K	COB/SMD 5730	1380-1420LM	120°
GNH-DL-WP-1 6W-A	16W	AC85-265V	108*50mm	Φ95mm	2700-6500K	COB/SMD 5730	1480-1530LM	120°

2. **Dimensional Drawing**(Unit: mm):

Size of waterproof Round LED Downlight

5W, 7W, 9W, Waterproof led downlight

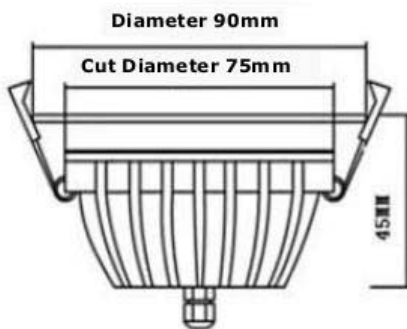

10W, 12W, 15W, 16W Waterproof led downlight

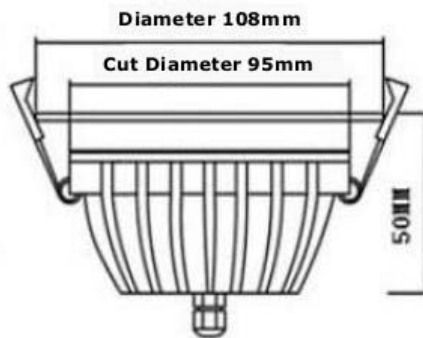



3. Packing details

Part No.	Packing Box	Outer Carton	Weight
GNH-DL-WP-5W-A	130*130*90mm	400*670*200mm 30pcs/carton	420g/pc
GNH-DL-WP-7W-A			467g/pc
GNH-DL-WP-9W-A			490g/pc
GNH-DL-WP-10W-A	150*150*95mm	470*620*210mm 24pcs/carton	720g/pc
GNH-DL-WP-12W-A			755g/pc
GNH-DL-WP-15W-A			780g/pc
GNH-DL-WP-16W-A			790g/pc

4. Application:

As usual they are widely used Hotels, Hospitals, Commercial Complexes, Conference / Meeting rooms, Factories & Offices, Residential / Institution Buildings, Schools and so on.

