



Greenough

Greenough Enterprises Co., Ltd.

LED luminaries Manufacturer and Exporter

Specification of MN03 LED Flood Light

Item: GNH-FL-MN03-100W-H01

Power: 100W

Date: June, 11th, 2015

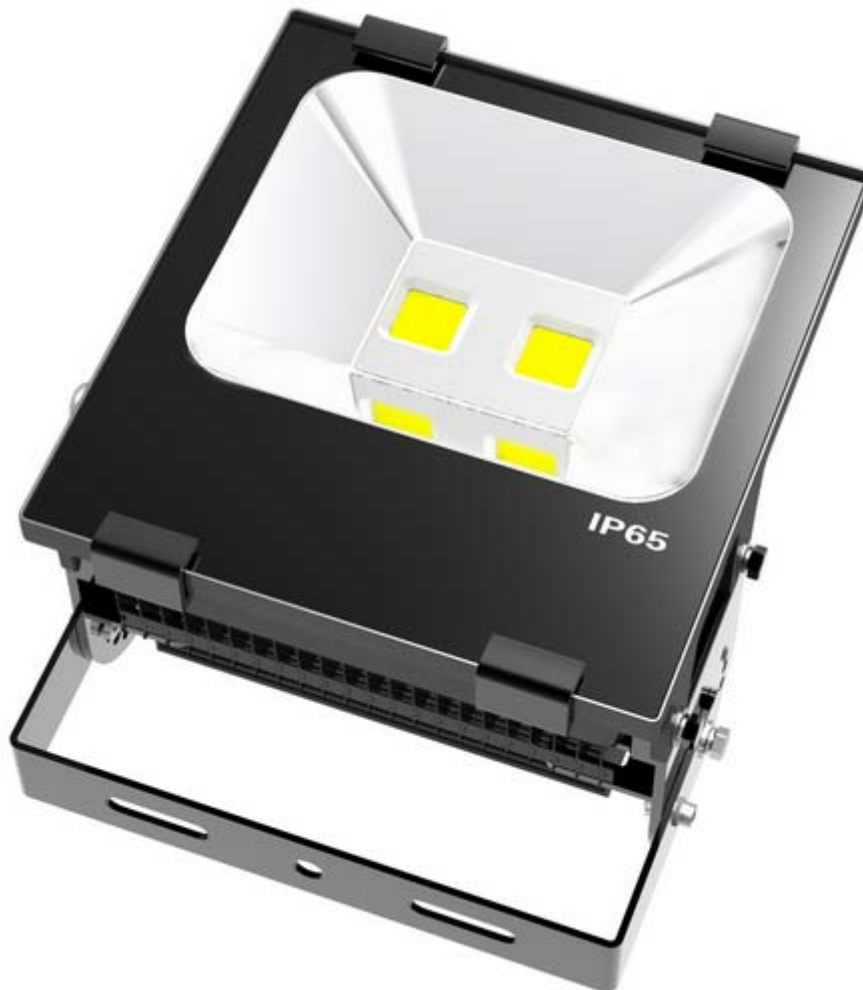



I. Product introduction

Characteristics

1. COB LEDs as light source. High Luminous Efficiency, Long life span.
2. Adoption of constant-current to control the circuit.
3. Die-casting aluminum cover.
4. Toughened glass, high temperature resistant silicon rubber sealing belt.
5. Environmental friendly: no pollution, cold light source design, no heat radiation, no lead, mercury and other pollution elements.
6. Start without delay, Reach full brightness quickly after power on.
7. The inside and outside of the led flood light is strong shockproof
8. Easily replace halogen, sodium or iodine lights and significantly reduce the energy consumption.
9. The Flood Lights are easy to install and have a lifetime of 50,000 hours.
10. The aluminum body is available in black and gray. The Flood Light is available in warm white, natural white and cold white.
11. Comply with CE and RHOS complaint



II. Specifications, parameters

1. Dimensional Drawing:

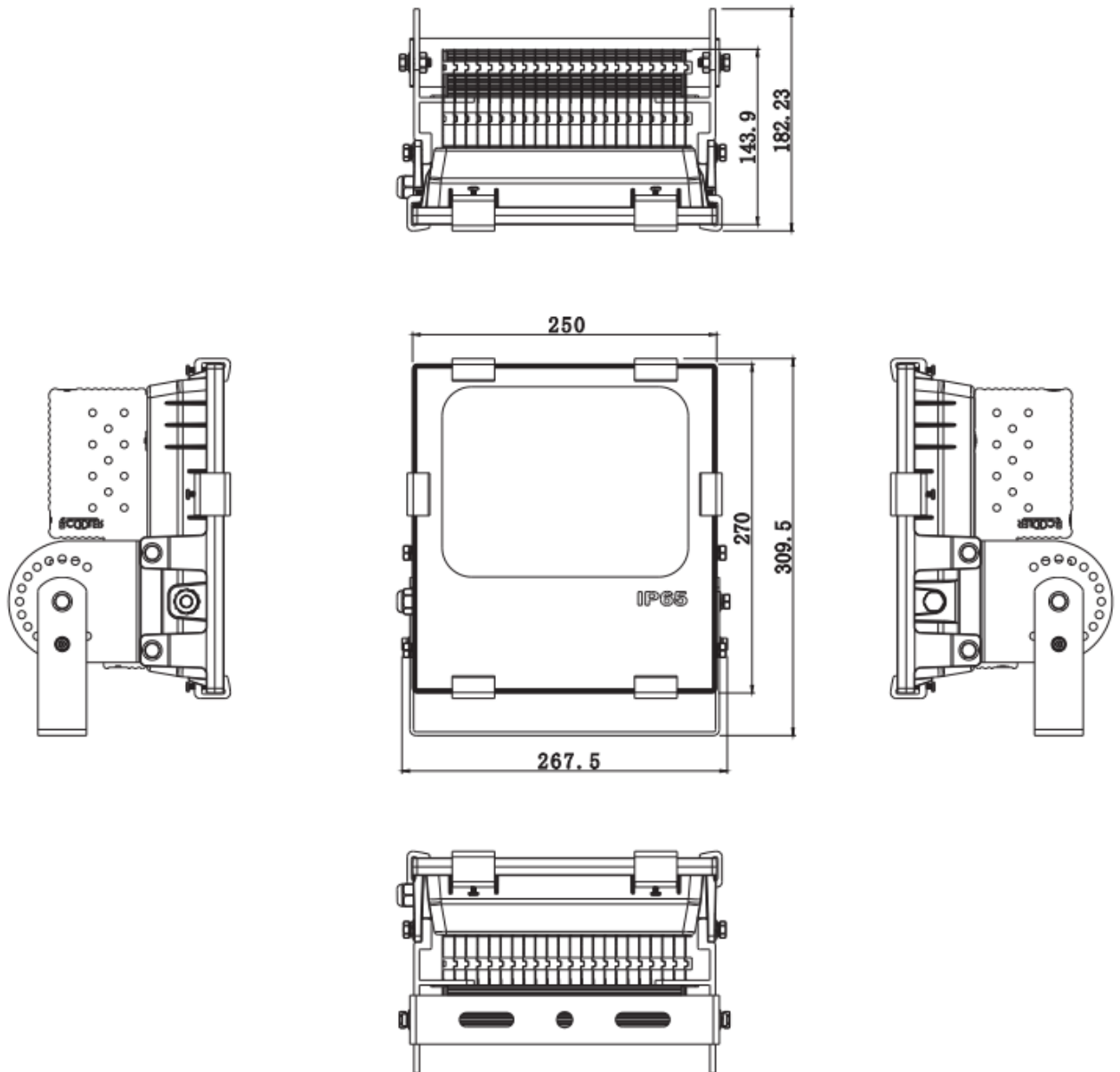



2. LED lighting technical parameters (***) Note: Different CCT LEDs has different optical properties. The deviation is less than 5% (***)

Model No.	LED No. (pcs)	Voltage (AC)	Size (MM)	Power	CCT	LED style	Flux(LM)	Beam angle	CRI(Ra)
GNH-FL-MN03-100W-HOI	2	85-265V	309*250*116	100W	2800-6500K	Bridgelux	10000LM	120°	70

3. LUX DIAGRAM:

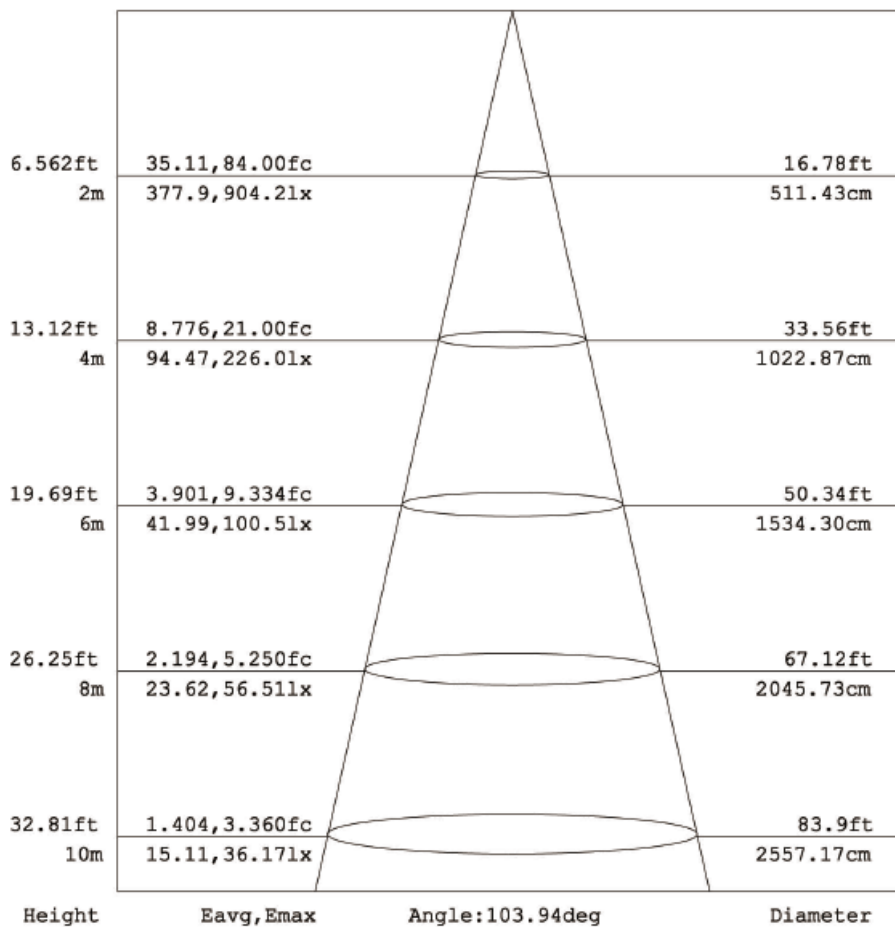

Note: The Curves indicate the illuminated area and the average illumination when the luminaire is at different distance.

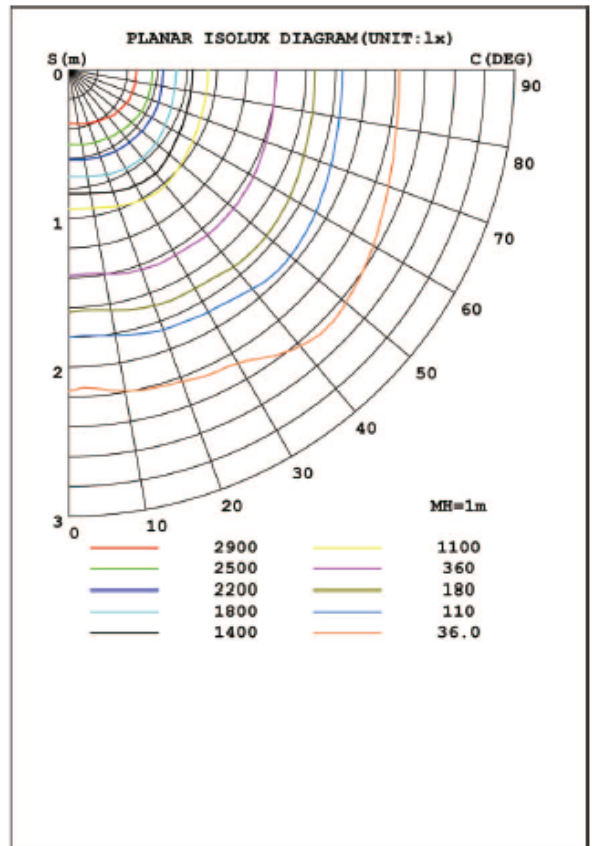
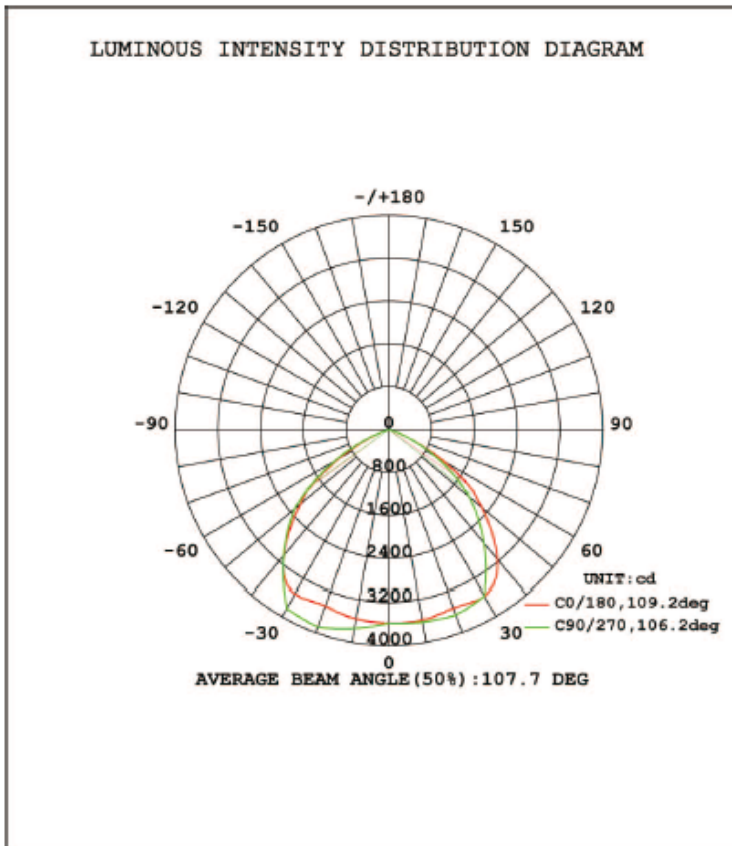

4. LED Life Prediction:

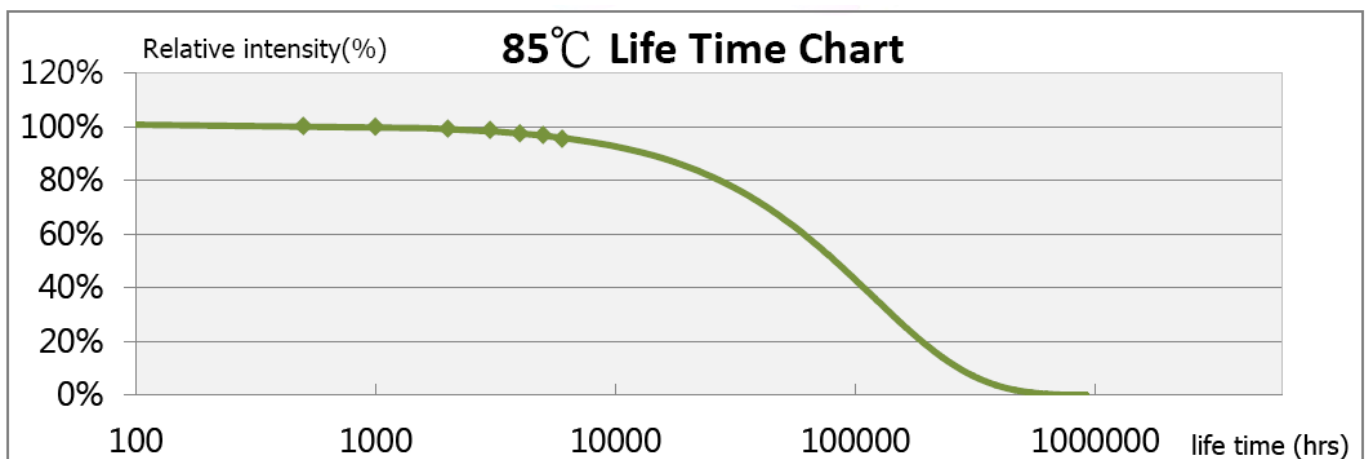



5. Installation:

1. First, adjust the angle you need, finally fasten the flood lights with screw.
2. Install the LED floodlight onto the wall or ground, punch hole on the wall or ground, prepare the expansion screw, and then fasten the flood light.
3. Connect the power wire from the Main line to the power wire of the lamp, and then make treatment for water resistance. Please note that the Brown color wire is Live wire, Blue wire is Null line, the yellow and green wire is Earth line.
4. Turn on the power supply to ensure the light is working. Then installed.

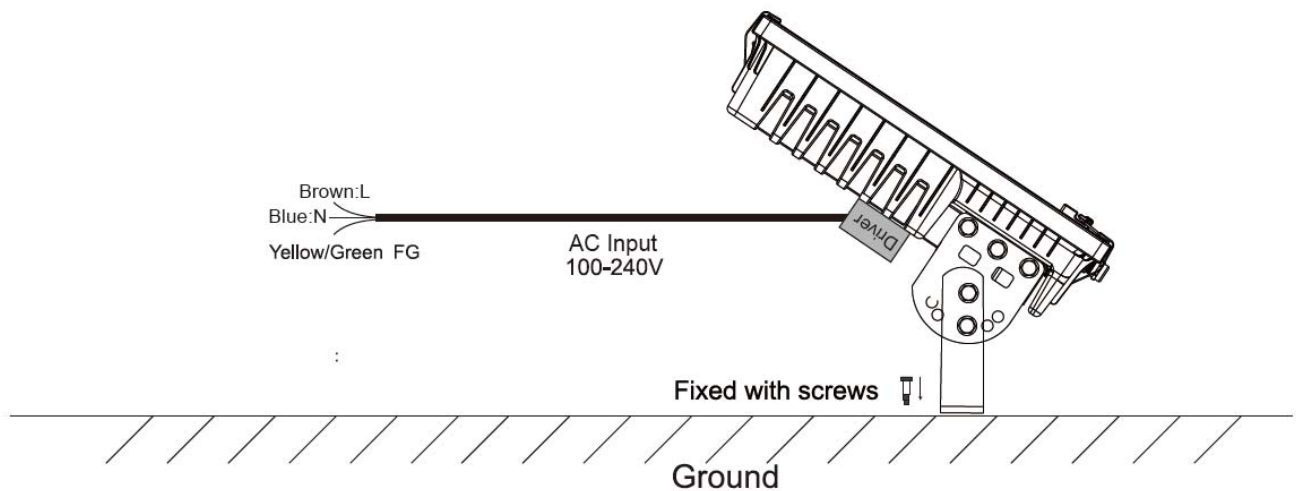

6. Circuit Connection Diagram:

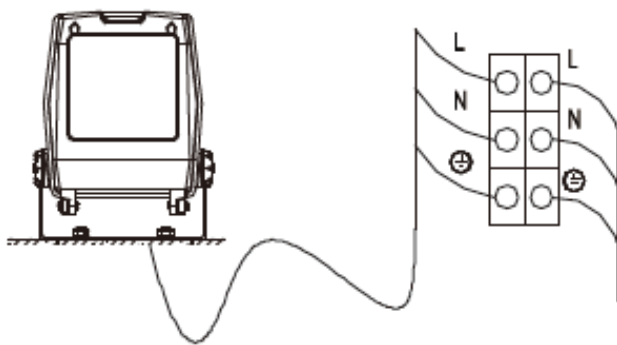

Attention:

1. Please turn off the power supply before installation or changing the assembling parts.
2. The input voltage and the lamp should be adapted. After connecting the power line, please make sure the wiring section is insulated.
3. Non-professionals must not install or dismantle the lamps.
4. All the flood lights during installation and in use should not be put with glass cover vertically upside.



7. Packingway:

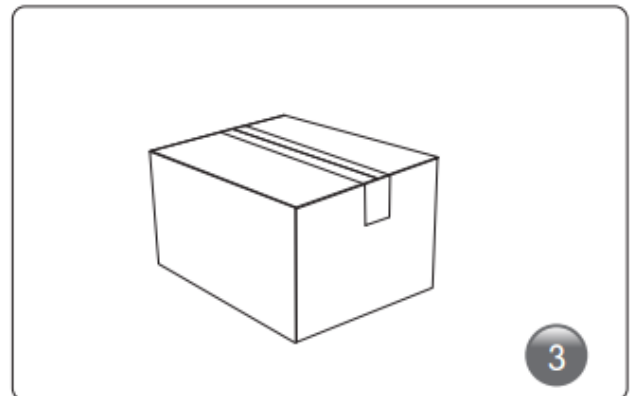
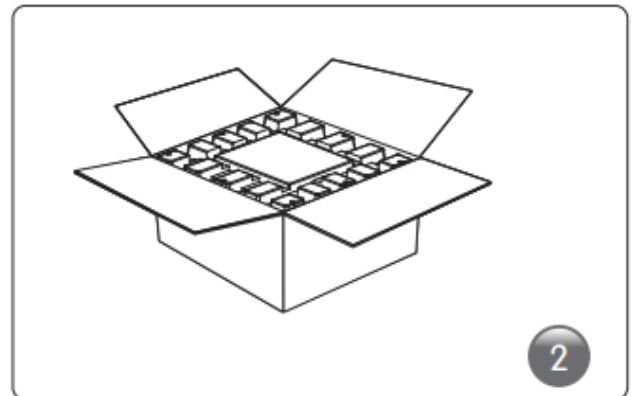
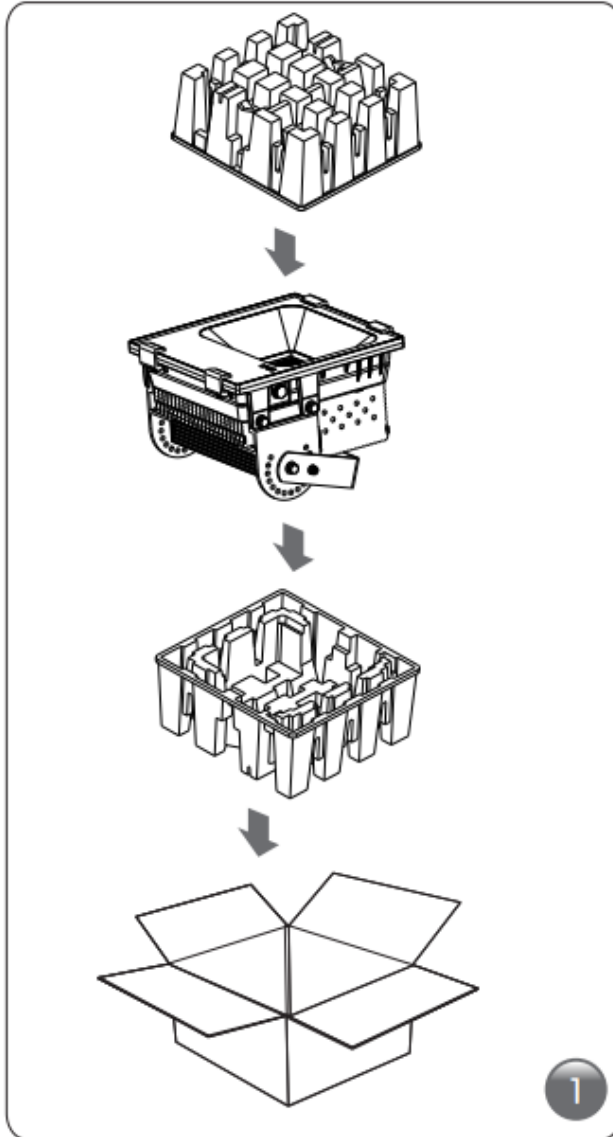

Part No.	Package dimension	Net Weight/one lamp	Gross Weight
GNH-FL-MN03-100 W-H01	370*350*250mm, 1pcs/carton	5.5.00kg/pc	6.0kg



Greenough

Greenough Enterprises Co., Ltd.

LED luminaries Manufacturer and Exporter

8. Applications:

LED flood light was used widely, such as: Tunnel light, Sports field, Parking lot, Garden, Residential area, Landscape, Architectural decorative lighting, Roads and other places.

